



„KATES POLSKA” Sp. z o.o.
10-467 Olsztyn, ul. Sprzętowa 3B

Tel. +4889/ 533 39 24, 533 53 03; Tel./Fax +4889/ 533 54 44
E-mail: kates@kates.com.pl; <http://www.kates.com.pl>

Manufacturer of equipment for pharmaceutical, chemical and food industries

VESSELS AND VESSEL EQUIPMENT

The KATES company has long-standing experience in designing and fabricating equipment for food, chemical and pharmaceutical industries. Our equipment may be produced in a wide range of fittings and structures. The list below provides a brief outline of particular components of the equipment we construct.

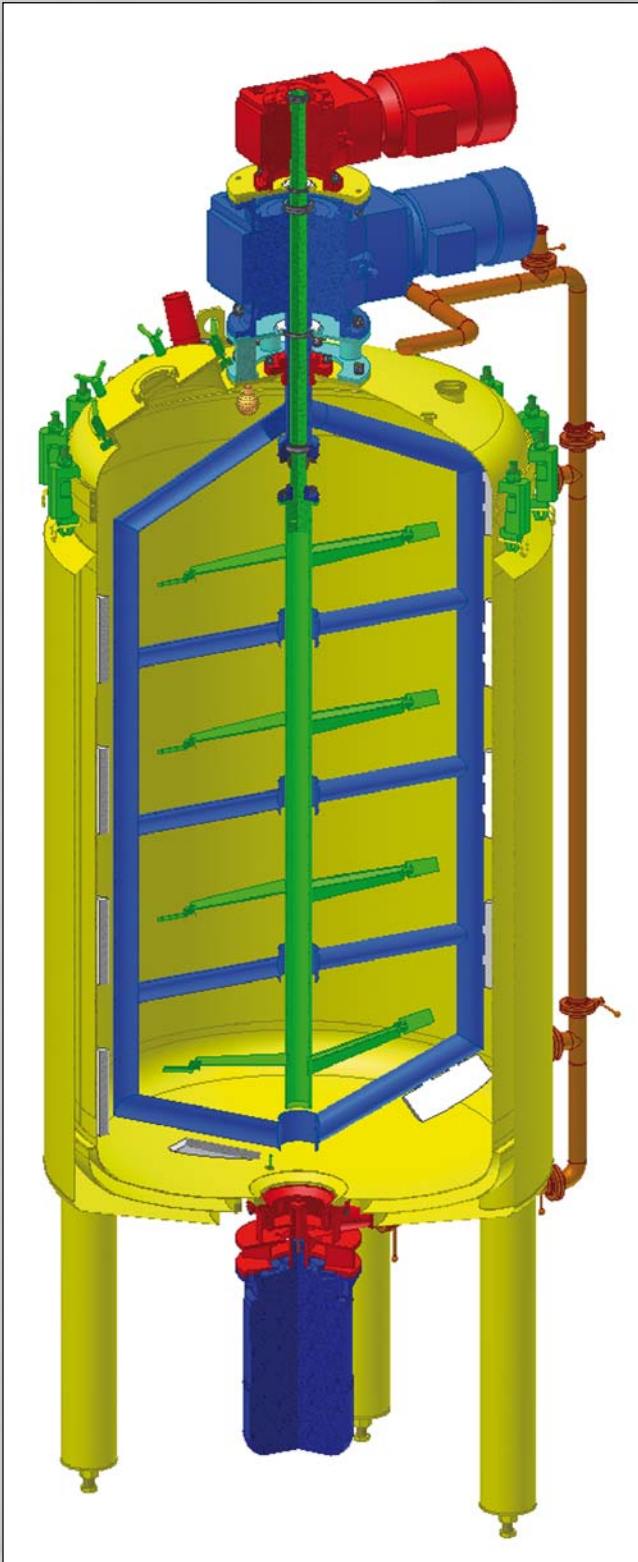

1. Heads:
 - conical,
 - flat,
 - press-formed ellipsoidal.
2. Internal or external shells of any diameter in the shape of a cylinder or cone – external or internal operating pressure.
3. Cooling jackets, heating jackets or cooling and heating jackets – fed with water, steam or other liquids:
 - conduit,
 - sectional,
 - coil,
 - pillow plate.
4. Insulation with a hermetic mantle.
5. Slow-speed agitators:
 - gate agitators with scrapers,
 - paddle agitators,
 - horseshoe agitators,
 - planetary-motion worm agitators,
 - counterrotating dual agitators,
 - agitators with static baffles, and compilations of agitators.
6. High-speed agitators:
 - turbine agitators,
 - homogenizing agitators,
 - homogenizing agitators with external cycle,
 - disc agitators.
7. Technological stub pipes with fittings:
 - round or oval hatch,
 - washing stub pipes with wash turbines or bowls,
 - breather valves,
 - glass inspection openings,
 - test valves,
 - steam injection valves,
 - technological and draining valves.
8. Weighing systems, extensometers.
9. Upper lid lifting systems:
 - vertical,
 - swinging.
10. Control units.

The devices may be used in any configuration according to the customer's individual requirements.

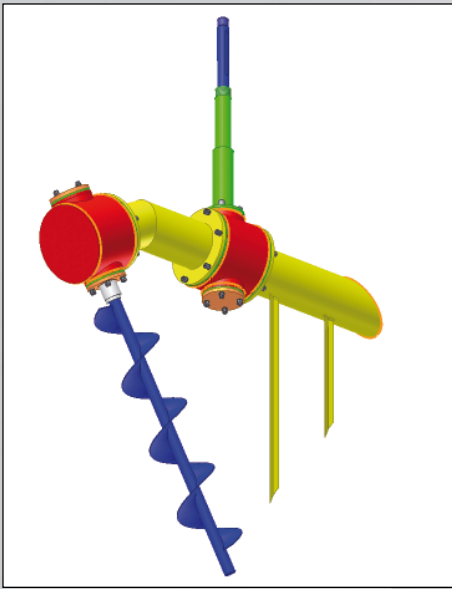

A planetary-motion worm agitator

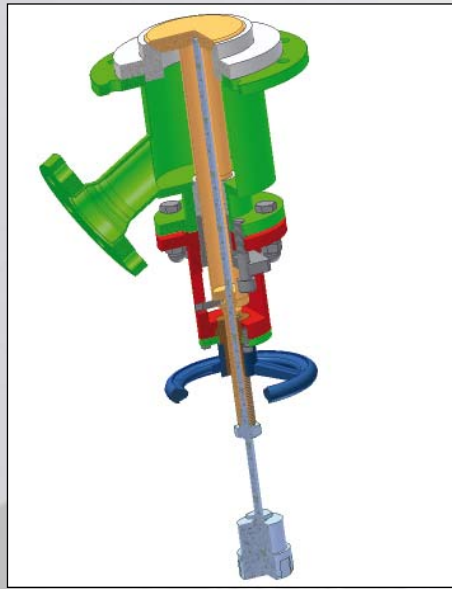

A draining valve



A turbine mixer

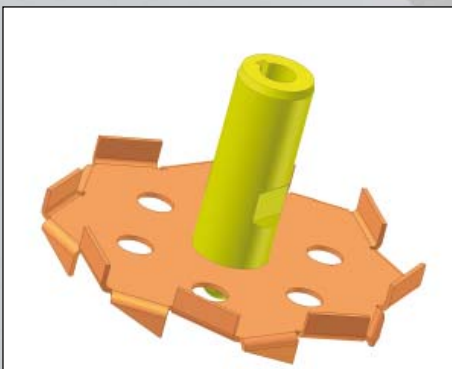

A disc agitator

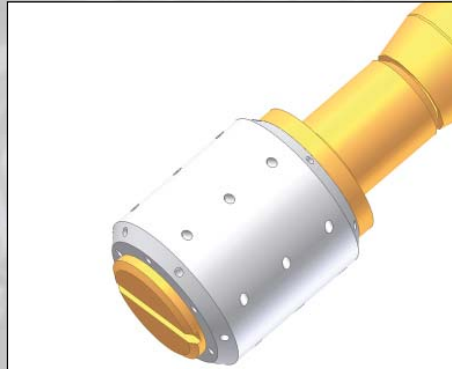

A washing turbine

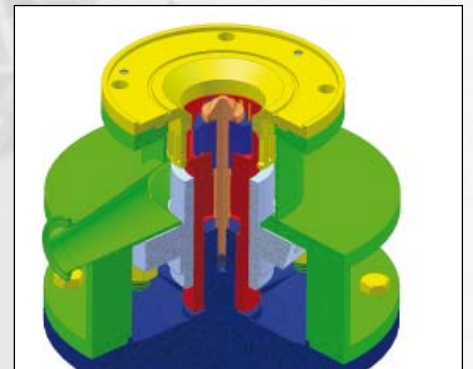

A homogenizing agitator

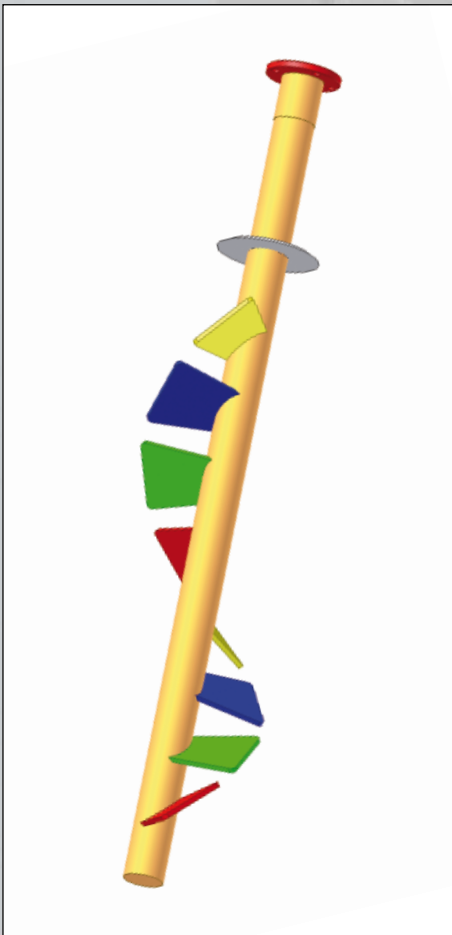

A multi-paddle agitator

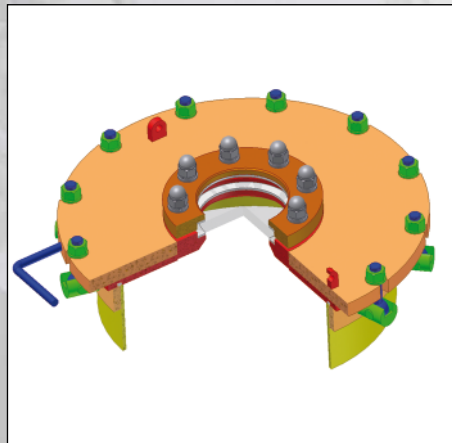

A pressure hatch with an inspection opening

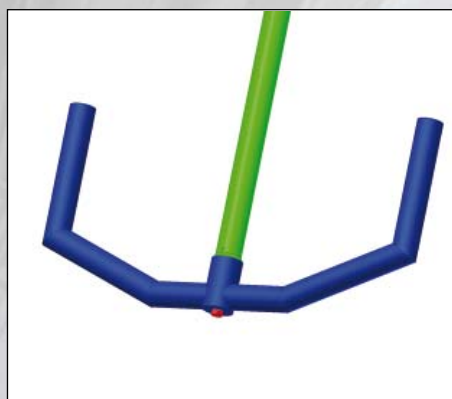

A horseshoe agitator

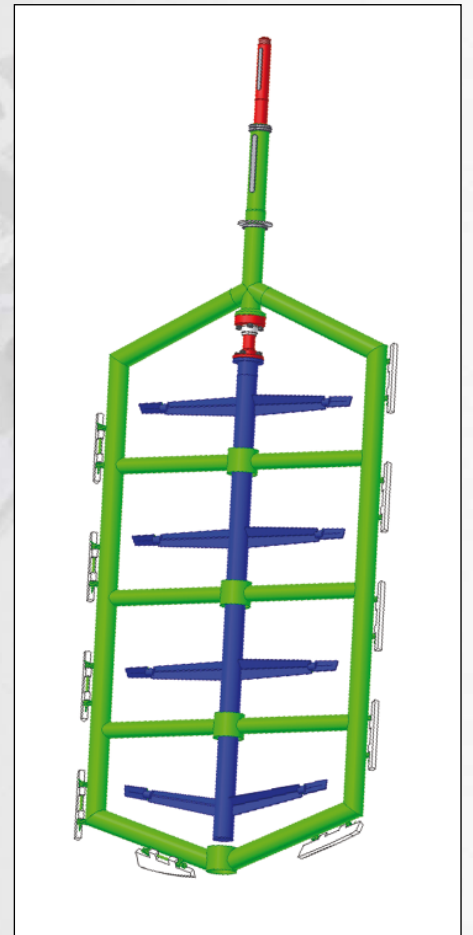

A gate agitator with scrapers and a counter-rotating paddle agitator